

AKZ4561/..KD-3.81-BASALTGREY

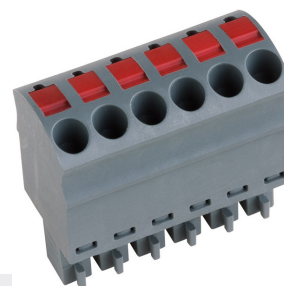

A Phoenix Mecano Brand



Technical Data

Wire sizes		Insulating Material	
Solid min	0.14 mm ²	Material	PA 6.6
Solid max	2.5 mm ²	Flammability Class	UL 94 V-0
Stranded (flexible) min	0.14mm ²	Temperatures	
Stranded (flexible) max	1.5 mm ²	Operating Temperature (without mech. load)	-40 °C - 105 °C
Stranded with Ferrule min	0.25 mm ²	Store Temperature	-40 °C - 105 °C
Stranded with Ferrule max	1.0 mm ²	Wave Soldering Process	
Dimensions		Soldering Temperature, recommended	-
Stripped Length	11.0 mm	Peak Soldering Time, recommended	-
Materials		Reflow Process	
Contact Spring	Copper Alloy	Soldering Temperature, recommended	-
Clamp Spring	Stainless Steel	Peak Soldering Time, recommended	-

Colours

	BASALT GREY, RAL 7012
	GREEN, RAL 6018
	LIGHT GREEN, similar RAL 6018

Colours according to RAL, there may be variations on colour due to production conditions. Special colours on request.

Counterparts (Spacing 3.81 mm)

Pin Strip/Terminal Block			
STLZ1550	STLZ1570	STLZ1590	AKZ5950

In combination of connectors with different admission data, the lower value is valid.

Order Data (Spacing 3.81 mm)

Poles	Width (mm)	Article Designation	Article Number	PU
2	7.62	AKZ4561/2KD-3.81-BASALTGREY	54561020421 F	200
3	11.43	AKZ4561/3KD-3.81-BASALTGREY	54561030421 F	200
4	15.24	AKZ4561/4KD-3.81-BASALTGREY	54561040421 F	200
5	19.05	AKZ4561/5KD-3.81-BASALTGREY	54561050421 F	200
6	22.86	AKZ4561/6KD-3.81-BASALTGREY	54561060421 E	100
7	26.67	AKZ4561/7KD-3.81-BASALTGREY	54561070421 E	100
8	30.48	AKZ4561/8KD-3.81-BASALTGREY	54561080421 D	50
9	34.29	AKZ4561/9KD-3.81-BASALTGREY	54561090421 D	50
10	38.10	AKZ4561/10KD-3.81-BASALTGREY	54561100421 D	50
11	41.91	AKZ4561/11KD-3.81-BASALTGREY	54561110421 D	50
12	45.72	AKZ4561/12KD-3.81-BASALTGREY	54561120421 D	50
13	49.53	AKZ4561/13KD-3.81-BASALTGREY	54561130421 D	50
14	53.34	AKZ4561/14KD-3.81-BASALTGREY	54561140421 D	50
15	57.15	AKZ4561/15KD-3.81-BASALTGREY	54561150421 D	50
16	60.96	AKZ4561/16KD-3.81-BASALTGREY	54561160421 D	50
17	64.77	AKZ4561/17KD-3.81-BASALTGREY	54561170421 D	50
18	68.58	AKZ4561/18KD-3.81-BASALTGREY	54561180421 D	50
19	72.39	AKZ4561/19KD-3.81-BASALTGREY	54561190421 D	50
20	76.20	AKZ4561/20KD-3.81-BASALTGREY	54561200421 D	50

Accessoires

Figure	Designation	Article Number
	Series AK(Z)4561 with pull relief	Order Data: on request

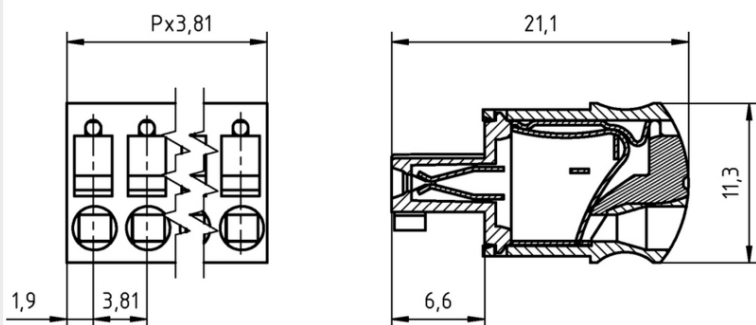

Ratings

UseGroup	C _{RU} US			VDE	
	B	C	D		
Rated Voltage	300 V	-	300 V	160 V	
Rated Current	10 A	-	10 A	10 A	
Overvoltage Category				III	
Rated Wire Size			min		max
- solid	AWG 26-16	-	AWG 26-16	0.14 mm ² (3 A)	2.5 mm ² (10 A)
- stranded	AWG 26-16	-	AWG 26-16	0.14 mm ² (3 A)	1.5 mm ² (10 A)
Test Voltage	1.60 kV	-	1.60 kV	2.5 kV	
Pollution Degree				3	