

AKZ350/..-10.16-V-GREEN-FP



Technical Data

Wire sizes		Insulating Material	
Solid min	0.14 mm ²	Material	PA 6.6
Solid max	2.5 mm ²	Flammability Class	UL 94 V-0
Stranded (flexible) min	0.14mm ²	Temperatures	
Stranded (flexible) max	1.5 mm ²	Operating Temperature (without mech. load)	-40 °C - 105 °C
Stranded with Ferrule min	0.25 mm ²	Store Temperature	-40 °C - 105 °C
Stranded with Ferrule max	1.5 mm ²	Wave Soldering Process	
Dimensions		Soldering Temperature, recommended	260 °C
Stripped Length	6.0 mm	Peak Soldering Time, recommended	3-4 s
PCB Hole Diameter	1.3 mm	Reflow Process	
Materials		Soldering Temperature, recommended	-
Clamp	Brass	Peak Soldering Time, recommended	-
Screw	Steel		
Solder Tab	Copper Alloy		

Colours

GREEN, RAL 6018

Colours according to RAL, there may be variations on colour due to production conditions. Special colours on request.

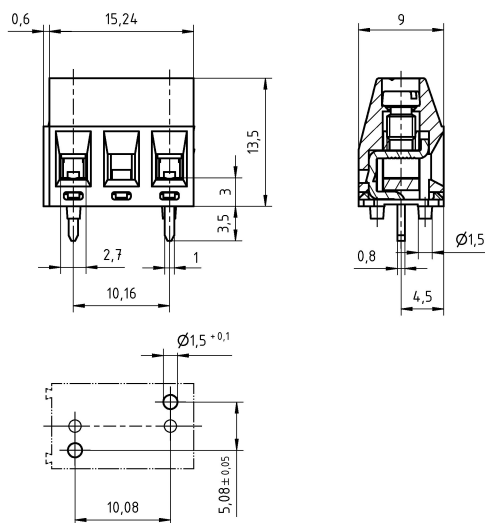

Order Data (Spacing 10.16 mm)

Poles	Width (mm)	Article Designation	Article Number	PU
2	15.84	AKZ350/2-10.16-V-GREEN-FP	50350020029 F	200

Ratings

UseGroup				**	
	B	C	D		
Rated Voltage	300 V	150 V	300 V	1.000 V	
Rated Current	15 A	15 A	10 A	17.5 A	
Rated Wire Size				min	max
- solid	AWG 22-12	AWG 22-12	AWG 22-12	0.5 mm ²	2.5 mm ²
- stranded	AWG 22-12	AWG 22-12	AWG 22-12	0.5 mm ²	1.5 mm ²
Torque	0.50 Nm	0.50 Nm	0.50 Nm	0.50 Nm	
Screw Size	M3	M3	M3	M3	
Test Voltage	1.60 kV	1.30 kV	1.60 kV	3.5 kV	

** Data similar to EN 60998