

AK700/..-10.0-V-GREEN



A Phoenix Mecano Brand

Technical Data

Wire sizes		Insulating Material	
Solid min	0.2 mm ²	Material	PA 6.6
Solid max	4.0 mm ²	Flammability Class	UL 94 V-0
Stranded (flexible) min	0.2mm ²	Temperatures	
Stranded (flexible) max	2.5 mm ²	Operating Temperature (without mech. load)	-40 °C - 105 °C
Stranded with Ferrule min	0.25 mm ²	Store Temperature	-40 °C - 105 °C
Stranded with Ferrule max	2.5 mm ²	Wave Soldering Process	
Dimensions		Soldering Temperature, recommended	260 °C
Stripped Length	8.0 mm	Peak Soldering Time, recommended	3-4 s
PCB Hole Diameter	1.3 mm	Reflow Process	
Materials		Soldering Temperature, recommended	-
Clamp	Brass	Peak Soldering Time, recommended	-
Screw	Steel		
Solder Tab	Copper Alloy		

Colours

	GREEN, RAL 6018
	GREY, RAL 7016
	PEBBLE GREY, RAL 7032
	BLUE, RAL 5015
	LIGHT GREEN, similar RAL 6018

Colours according to RAL, there may be variations on colour due to production conditions. Special colours on request.

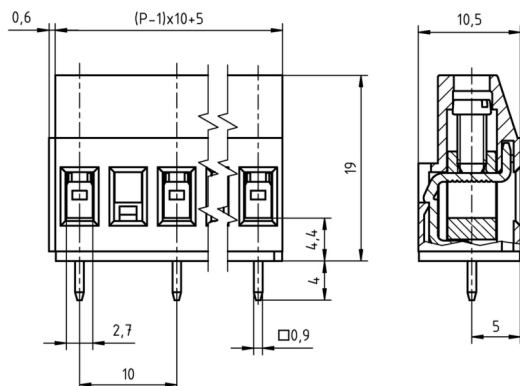

Order Data (Spacing 10.0 mm)

Poles	Width (mm)	Article Designation	Article Number	PU
2	15.60	AK700/2-10.0-V-GREEN	50700020241 F	200
3	25.60	AK700/3-10.0-V-GREEN	50700030241 F	200
4	35.60	AK700/4-10.0-V-GREEN	50700040241 E	100
5	45.60	AK700/5-10.0-V-GREEN	50700050241 E	100
6	55.60	AK700/6-10.0-V-GREEN	50700060241 D	50

Accessoires

Figure	Designation	Article Number
	Screw Cover SC-AK700-YELLOW	Order Data: 50700000004

Ratings

UseGroup	C _{RU} US			VDE	
	B	C	D		
Rated Voltage	300 V	150 V	300 V	1.000 V	
Rated Current	20 A	20 A	10 A	24 A	
Rated Wire Size				min	max
- solid	AWG 30-12	AWG 30-12	AWG 30-12	0.5 mm ²	4.0 mm ²
- stranded	AWG 30-12	AWG 30-12	AWG 30-12	0.5 mm ²	2.5 mm ²
Torque	0.45 Nm	0.45 Nm	0.45 Nm	0.50 Nm	
Screw Size	M3	M3	M3	M3	
Test Voltage	1.60 kV	1.30 kV	1.60 kV	3.5 kV	