

# AK4101/..KD-5.0-PEBBLE GREY



A Phoenix Mecano Brand

- 1 to n poles

## Technical Data

Wire sizes		Insulating Material	
Solid min	0.08 mm <sup>2</sup>	Material	PA 6.6
Solid max	2.5 mm <sup>2</sup>	Flammability Class	UL 94 V-0
Stranded (flexible) min	0.5 mm <sup>2</sup>	<b>Temperatures</b>	
Stranded (flexible) max	1.5 mm <sup>2</sup>	Operating Temperature (without mech. load)	-40 °C - 105 °C
Stranded with Ferrule min	0.14 mm <sup>2</sup>	Store Temperature	-40 °C - 105 °C
Stranded with Ferrule max	1.0 mm <sup>2</sup>	<b>Wave Soldering Process</b>	
<b>Dimensions</b>		Soldering Temperature, recommended	260 °C
Stripped Length	9.0 mm	Peak Soldering Time, recommended	3-4 s
PCB Hole Diameter	1.0 mm	<b>Reflow Process</b>	
<b>Materials</b>		Soldering Temperature, recommended	-
Solder Tab	Copper Alloy	Peak Soldering Time, recommended	-
Clamp Spring	Stainless Steel		

## Colours

	PEBBLE GREY, RAL 7032
	BLUE, RAL 5015

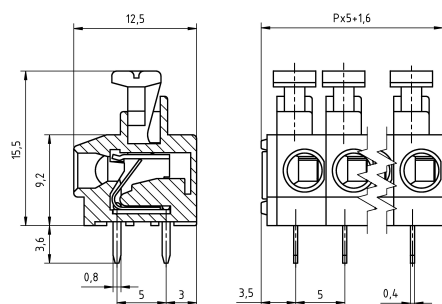

Colours according to RAL, there may be variations on colour due to production conditions. Special colours on request.



## Order Data (Spacing 5.0 mm)

Poles	Width (mm)	Article Designation	Article Number	PU
1	6.60	AK4101/1KD-5.0-PEBBLE GREY	54101010001 G	250
2	11.60	AK4101/2KD-5.0-PEBBLE GREY	54101020001 F	200
3	16.60	AK4101/3KD-5.0-PEBBLE GREY	54101030001 F	200
4	21.60	AK4101/4KD-5.0-PEBBLE GREY	54101040001 E	100
5	26.60	AK4101/5KD-5.0-PEBBLE GREY	54101050001 E	100
6	31.60	AK4101/6KD-5.0-PEBBLE GREY	54101060001 D	50
7	36.60	AK4101/7KD-5.0-PEBBLE GREY	54101070001 D	50
8	41.60	AK4101/8KD-5.0-PEBBLE GREY	54101080001 D	50
9	46.60	AK4101/9KD-5.0-PEBBLE GREY	54101090001 D	50
10	51.60	AK4101/10KD-5.0-PEBBLE GREY	54101100001 D	50
11	56.60	AK4101/11KD-5.0-PEBBLE GREY	54101110001 D	50
12	61.60	AK4101/12KD-5.0-PEBBLE GREY	54101120001 D	50

## Accessoires

Figure	Designation	Article Number
	Bridge, 2-pole, insulated, BRI/2-5.0/5.08-LIGHT GREY	Order Data: 50000000006
	Bridge, 3-pole, insulated, BRI/3-5.0/5.08-LIGHT GREY	Order Data: 50000000007

## Ratings



UseGroup	B	C	D		
Rated Voltage	300 V	-	300 V	250 V	
Rated Current	10 A	-	10 A	17.5 A	
Rated Wire Size				min	max
- solid	AWG 20-14	-	AWG 20-14	0.5 mm <sup>2</sup>	2.5 mm <sup>2</sup>
- stranded	-	-	-	-	-
Test Voltage	1.60 kV	-	1.60 kV	2.0 kV	