



AKZ1710/..-7.62-GREEN



Technical Data

Wire sizes		Insulating Material	
Solid min	0.14 mm ²	Material	PA 6.6
Solid max	1.5 mm ²	Flammability Class	UL 94 V-0
Stranded (flexible) min	0.14mm ²	Temperatures	
Stranded (flexible) max	1.5 mm ²	Operating Temperature (without mech. load)	-40 °C - 105 °C
Stranded with Ferrule min	0.25 mm ²	Store Temperature	-40 °C - 105 °C
Stranded with Ferrule max	1.0 mm ²	Wave Soldering Process	
Dimensions		Soldering Temperature, recommended	-
Stripped Length	7.0 mm	Peak Soldering Time, recommended	-
Materials		Reflow Process	
Clamp	Brass	Soldering Temperature, recommended	-
Screw	Bronze	Peak Soldering Time, recommended	-
Contact Spring	Bronze		

Colours

	LIGHT GREY, RAL 7035
	GREEN, RAL 6018
	LIGHT GREEN, similar RAL 6018

Colours according to RAL, there may be variations on colour due to production conditions. Special colours on request.

Counterparts (Spacing 7.62 mm)

Pin Strip		
STLZ1550	STLZ1570	STLZ1590

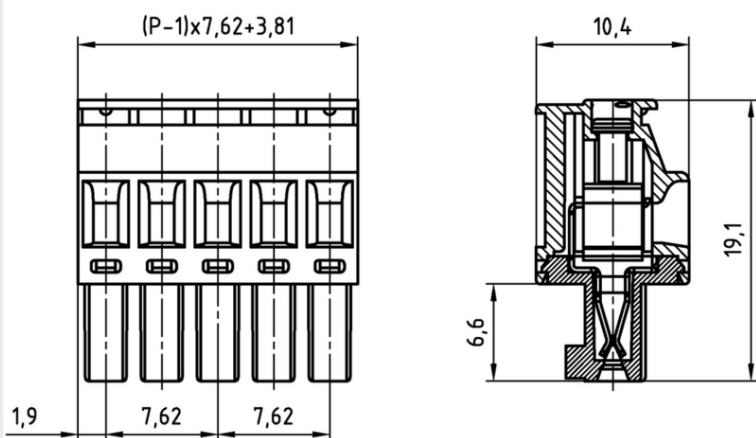

In combination of connectors with different admission data, the lower value is valid.



Order Data (Spacing 7.62 mm)

Poles	Width (mm)	Article Designation	Article Number	PU
2	11.43	AKZ1710/2-7.62-GREEN	51710020061 F	200
3	19.05	AKZ1710/3-7.62-GREEN	51710030061 F	200
4	26.67	AKZ1710/4-7.62-GREEN	51710040061 E	100
5	34.29	AKZ1710/5-7.62-GREEN	51710050061 E	100
6	41.91	AKZ1710/6-7.62-GREEN	51710060061 D	50
7	49.53	AKZ1710/7-7.62-GREEN	51710070061 D	50
8	57.15	AKZ1710/8-7.62-GREEN	51710080061 D	50
9	64.77	AKZ1710/9-7.62-GREEN	51710090061 D	50
10	72.39	AKZ1710/10-7.62-GREEN	51710100061 D	50

Accessoires

Figure	Designation	Article Number
	Bridge, 2-pole, insulated, BRI/2-7.0/7.62-L7.5-LIGHT GREY	Order Data: 50000000018
	Series AK(Z)1710 with pull relief	Order Data: on request

Ratings

UseGroup	cRU [®] US			VDE	
	B	C	D		
Rated Voltage	300 V	-	300 V	500 V	
Rated Current	8 A	-	8 A	8 A	
Overvoltage Category				III	
Rated Wire Size			min		max
- solid	AWG 28-16	-	AWG 28-16	0.5 mm ² (6 A)	1.5 mm ² (8 A)
- stranded	AWG 28-16	-	AWG 28-16	0.5 mm ² (6 A)	1.5 mm ² (8 A)
Torque	0.25 Nm	-	0.25 Nm	0.25 Nm	
Screw Size	M2	-	M2	M2	
Test Voltage	1.60 kV	-	1.60 kV	6.0 kV	
Pollution Degree				3	