

AKZ1550/..F-7.62-GREEN

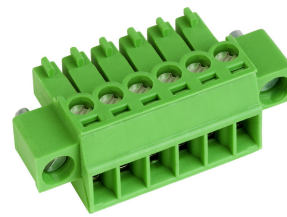

Technical Data

| Wire sizes | | Insulating Material | |
|---------------------------|----------------------|--|-----------------|
| Solid min | 0.14 mm ² | Material | PA 6.6 |
| Solid max | 1.5 mm ² | Flammability Class | UL 94 V-0 |
| Stranded (flexible) min | 0.14mm ² | Temperatures | |
| Stranded (flexible) max | 1.5 mm ² | Operating Temperature (without mech. load) | -40 °C - 105 °C |
| Stranded with Ferrule min | 0.25 mm ² | Store Temperature | -40 °C - 105 °C |
| Stranded with Ferrule max | 1.0 mm ² | Wave Soldering Process | |
| Dimensions | | Soldering Temperature, recommended | - |
| Stripped Length | 7.0 mm | Peak Soldering Time, recommended | - |
| Materials | | Reflow Process | |
| Clamp | Brass | Soldering Temperature, recommended | - |
| Screw | Bronze | Peak Soldering Time, recommended | - |
| Screw, Flange | Steel | | |
| Contact Spring | Bronze | | |

Colours

| | |
|--|-------------------------------|
| | BLACK, RAL 9011 |
| | GREEN, RAL 6018 |
| | LIGHT GREEN, similar RAL 6018 |

Colours according to RAL, there may be variations on colour due to production conditions. Special colours on request.

Counterparts (Spacing 7.62 mm)

| Pin Strip | |
|-----------|----------|
| STLZ1550 | STLZ1570 |

In combination of connectors with different admission data, the lower value is valid.

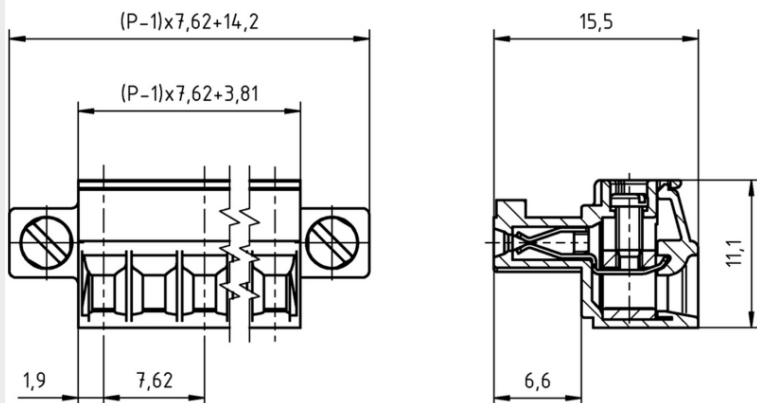

Order Data (Spacing 7.62 mm)

| Poles | Width (mm) | Article Designation | Article Number | PU |
|-------|------------|------------------------|----------------|-----|
| 2 | 21.03 | AKZ1550/2F-7.62-GREEN | 51550022065 E | 100 |
| 3 | 28.65 | AKZ1550/3F-7.62-GREEN | 51550032065 E | 100 |
| 4 | 36.27 | AKZ1550/4F-7.62-GREEN | 51550042065 E | 100 |
| 5 | 43.89 | AKZ1550/5F-7.62-GREEN | 51550052065 E | 100 |
| 6 | 51.51 | AKZ1550/6F-7.62-GREEN | 51550062065 D | 50 |
| 7 | 59.13 | AKZ1550/7F-7.62-GREEN | 51550072065 D | 50 |
| 8 | 66.75 | AKZ1550/8F-7.62-GREEN | 51550082065 D | 50 |
| 9 | 74.37 | AKZ1550/9F-7.62-GREEN | 51550092065 D | 50 |
| 10 | 81.99 | AKZ1550/10F-7.62-GREEN | 51550102065 D | 50 |

Accessoires

| Figure | Designation | Article Number |
|--------|---|-------------------------|
| | Bridge, 2-pole, insulated, BRI/2-7.0/7.62-L7.5-LIGHT GREY | Order Data: 50000000018 |
| | Series AK(Z)1550 with pull relief | Order Data: on request |

Ratings

| UseGroup | cRU [®] US | | | VDE | |
|----------------------|---------------------|-----------|-----------|---------------------------|---------------------------|
| | B | C | D | | |
| Rated Voltage | 300 V | 150 V | 300 V | 500 V | |
| Rated Current | 8 A | 8 A | - | 9 A | |
| Overvoltage Category | | | | III | |
| Rated Wire Size | | | | min | max |
| - solid | AWG 28-16 | AWG 28-16 | AWG 28-16 | 0.5 mm ² (6 A) | 1.5 mm ² (9 A) |
| - stranded | AWG 28-16 | AWG 28-16 | AWG 28-16 | 0.5 mm ² (6 A) | 1.5 mm ² (9 A) |
| Torque | 0.25 Nm | 0.25 Nm | 0.25 Nm | 0.25 Nm | |
| Screw Size | M2 | M2 | M2 | M2 | |
| Test Voltage | 1.60 kV | 1.30 kV | 1.60 kV | 6.0 kV | |
| Pollution Degree | | | | 3 | |