

AKZ1550/..F-3.81-GREEN

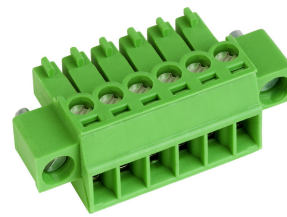

Technical Data

Wire sizes		Insulating Material	
Solid min	0.14 mm ²	Material	PA 6.6
Solid max	1.5 mm ²	Flammability Class	UL 94 V-0
Stranded (flexible) min	0.14mm ²	Temperatures	
Stranded (flexible) max	1.5 mm ²	Operating Temperature (without mech. load)	-40 °C - 105 °C
Stranded with Ferrule min	0.25 mm ²	Store Temperature	-40 °C - 105 °C
Stranded with Ferrule max	1.0 mm ²	Wave Soldering Process	
Dimensions		Soldering Temperature, recommended	-
Stripped Length	7.0 mm	Peak Soldering Time, recommended	-
Materials		Reflow Process	
Clamp	Brass	Soldering Temperature, recommended	-
Screw	Bronze	Peak Soldering Time, recommended	-
Screw, Flange	Steel		
Contact Spring	Bronze		

Colours

	GREEN, RAL 6018
	BLACK, RAL 9011
	LIGHT GREEN, similar RAL 6018

Colours according to RAL, there may be variations on colour due to production conditions. Special colours on request.

Counterparts (Spacing 3.81 mm)

Pin Strip	
STLZ1550	STLZ1570

In combination of connectors with different admission data, the lower value is valid.

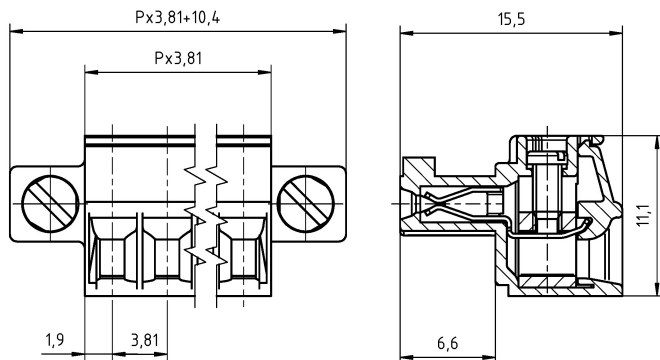

Order Data (Spacing 3.81 mm)

Poles	Width (mm)	Article Designation	Article Number	PU
2	17.22	AKZ1550/2F-3.81-GREEN	51550022025 F	200
3	21.03	AKZ1550/3F-3.81-GREEN	51550032025 F	200
4	24.84	AKZ1550/4F-3.81-GREEN	51550042025 F	200
5	28.65	AKZ1550/5F-3.81-GREEN	51550052025 F	200
6	32.46	AKZ1550/6F-3.81-GREEN	51550062025 E	100
7	36.27	AKZ1550/7F-3.81-GREEN	51550072025 D	50
8	40.08	AKZ1550/8F-3.81-GREEN	51550082025 D	50
9	43.89	AKZ1550/9F-3.81-GREEN	51550092025 D	50
10	47.70	AKZ1550/10F-3.81-GREEN	51550102025 D	50
11	51.51	AKZ1550/11F-3.81-GREEN	51550112025 D	50
12	55.32	AKZ1550/12F-3.81-GREEN	51550122025 D	50
13	59.13	AKZ1550/13F-3.81-GREEN	51550132025 D	50
14	62.94	AKZ1550/14F-3.81-GREEN	51550142025 D	50
15	66.75	AKZ1550/15F-3.81-GREEN	51550152025 D	50
16	70.56	AKZ1550/16F-3.81-GREEN	51550162025 D	50
17	74.37	AKZ1550/17F-3.81-GREEN	51550172025 D	50
18	78.18	AKZ1550/18F-3.81-GREEN	51550182025 D	50
19	81.99	AKZ1550/19F-3.81-GREEN	51550192025 D	50
20	85.80	AKZ1550/20F-3.81-GREEN	51550202025 D	50

Accessoires

Figure	Designation	Article Number
	Series AK(Z)1550 with pull relief	Order Data: on request
	Bridge, 2-pole, BR/2-3.5/3.81-L7.5	Order Data: 50000000015
	Bridge, 3-pole, BR/3-3.5/3.81-L7.5	Order Data: 50000000016
	Bridge, 2-pole, insulated, BR/2-7.0/7.62-L7.5-LIGHT GREY	Order Data: 50000000018
	Bridge, 2-pole, angled, BR/2-3.5/3.81-H-L7.5	Order Data: 50000000029

Ratings

UseGroup	cRU [®] US			VDE		
	B	C	D			
Rated Voltage	300 V	-	300 V	160 V		
Rated Current	8 A	-	8 A	8 A		
Overvoltage Category				III		
Rated Wire Size					min	max
	- solid	AWG 28-16	-	AWG 28-16	0.5 mm ² (6 A)	1.5 mm ² (8 A)
	- stranded	AWG 28-16	-	AWG 28-16	0.5 mm ² (6 A)	1.5 mm ² (8 A)
Torque	0.25 Nm	-	0.25 Nm	0.25 Nm		
Screw Size	M2	-	M2	M2		
Test Voltage	1.60 kV	-	1.60 kV	2.5 kV		
Pollution Degree					3	