

# AK4551/..KD-3.5-BASALTGREY

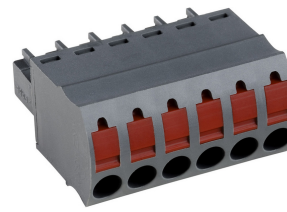

A Phoenix Mecano Brand

## Technical Data

Wire sizes		Insulating Material	
Solid min	0.14 mm <sup>2</sup>	Material	PA 6.6
Solid max	2.5 mm <sup>2</sup>	Flammability Class	UL 94 V-0
Stranded (flexible) min	0.14mm <sup>2</sup>	<b>Temperatures</b>	
Stranded (flexible) max	1.5 mm <sup>2</sup>	Operating Temperature (without mech. load)	-40 °C - 105 °C
Stranded with Ferrule min	0.25 mm <sup>2</sup>	Store Temperature	-40 °C - 105 °C
Stranded with Ferrule max	1.0 mm <sup>2</sup>	<b>Wave Soldering Process</b>	
<b>Dimensions</b>		Soldering Temperature, recommended	-
Stripped Length	11.0 mm	Peak Soldering Time, recommended	-
<b>Materials</b>		<b>Reflow Process</b>	
Contact Spring	Copper Alloy	Soldering Temperature, recommended	-
Clamp Spring	Stainless Steel	Peak Soldering Time, recommended	-

## Colours

	BASALT GREY, RAL 7012
	GREEN, RAL 6018
	LIGHT GREEN, similar RAL 6018

Colours according to RAL, there may be variations on colour due to production conditions. Special colours on request.

## Counterparts (Spacing 3.5 mm)

Pin Strip  
STL1550

In combination of connectors with different admission data, the lower value is valid.

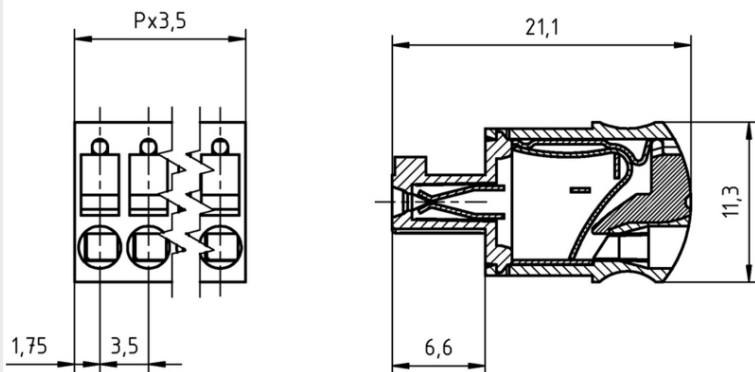

## Order Data (Spacing 3.5 mm)

Poles	Width (mm)	Article Designation	Article Number	PU
2	7.00	AK4551/2KD-3.5-BASALTGREY	54551020401 F	200
3	10.50	AK4551/3KD-3.5-BASALTGREY	54551030401 F	200
4	14.00	AK4551/4KD-3.5-BASALTGREY	54551040401 F	200
5	17.50	AK4551/5KD-3.5-BASALTGREY	54551050401 F	200
6	21.00	AK4551/6KD-3.5-BASALTGREY	54551060401 E	100
7	24.50	AK4551/7KD-3.5-BASALTGREY	54551070401 E	100
8	28.00	AK4551/8KD-3.5-BASALTGREY	54551080401 D	50
9	31.50	AK4551/9KD-3.5-BASALTGREY	54551090401 D	50
10	35.00	AK4551/10KD-3.5-BASALTGREY	54551100401 D	50
11	38.50	AK4551/11KD-3.5-BASALTGREY	54551110401 D	50
12	42.00	AK4551/12KD-3.5-BASALTGREY	54551120401 D	50
13	45.50	AK4551/13KD-3.5-BASALTGREY	54551130401 D	50
14	49.00	AK4551/14KD-3.5-BASALTGREY	54551140401 D	50
15	52.50	AK4551/15KD-3.5-BASALTGREY	54551150401 D	50
16	56.00	AK4551/16KD-3.5-BASALTGREY	54551160401 D	50
17	59.50	AK4551/17KD-3.5-BASALTGREY	54551170401 D	50
18	63.00	AK4551/18KD-3.5-BASALTGREY	54551180401 D	50
19	66.50	AK4551/19KD-3.5-BASALTGREY	54551190401 D	50
20	70.00	AK4551/20KD-3.5-BASALTGREY	54551200401 D	50

## Accessoires

Figure	Designation	Article Number
	Series AK(Z)4551 with pull relief	Order Data: on request

## Ratings

UseGroup	cRU <sup>®</sup> US			VDE		
	B	C	D			
Rated Voltage	300 V	-	300 V	160 V		
Rated Current	10 A	-	10 A	10 A		
Overvoltage Category				III		
Rated Wire Size	min					max
	- solid	AWG 26-16	-	AWG 26-16	0.14 mm <sup>2</sup> (3 A)	2.5 mm <sup>2</sup> (10 A)
	- stranded	AWG 26-16	-	AWG 26-16	0.14 mm <sup>2</sup> (3 A)	1.5 mm <sup>2</sup> (10 A)
Test Voltage	1.60 kV	-	1.60 kV	2.5 kV		
Pollution Degree						3