

# AK4551/..FKD-3.5-BASALTGREY

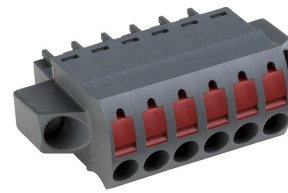

A Phoenix Mecano Brand

## Technical Data

Wire sizes		Insulating Material	
Solid min	0.14 mm <sup>2</sup>	Material	PA 6.6
Solid max	2.5 mm <sup>2</sup>	Flammability Class	UL 94 V-0
Stranded (flexible) min	0.14mm <sup>2</sup>	<b>Temperatures</b>	
Stranded (flexible) max	1.5 mm <sup>2</sup>	Operating Temperature (without mech. load)	-40 °C - 105 °C
Stranded with Ferrule min	0.25 mm <sup>2</sup>	Store Temperature	-40 °C - 105 °C
Stranded with Ferrule max	1.0 mm <sup>2</sup>	<b>Wave Soldering Process</b>	
<b>Dimensions</b>		Soldering Temperature, recommended	-
Stripped Length	11.0 mm	Peak Soldering Time, recommended	-
<b>Materials</b>		<b>Reflow Process</b>	
Screw, Flange	Steel	Soldering Temperature, recommended	-
Contact Spring	Copper Alloy	Peak Soldering Time, recommended	-
Clamp Spring	Stainless Steel		

## Colours

	BASALT GREY, RAL 7012
	GREEN, RAL 6018
	LIGHT GREEN, similar RAL 6018

Colours according to RAL, there may be variations on colour due to production conditions. Special colours on request.

## Counterparts (Spacing 3.5 mm)

Pin Strip  
STL1550

In combination of connectors with different admission data, the lower value is valid.

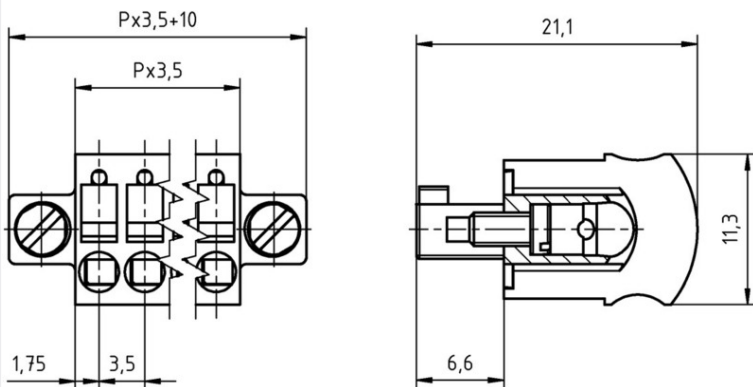

## Order Data (Spacing 3.5 mm)

Poles	Width (mm)	Article Designation	Article Number	PU
2	17.00	AK4551/2FKD-3.5-BASALTGREY	54551022401 F	200
3	20.50	AK4551/3FKD-3.5-BASALTGREY	54551032401 F	200
4	24.00	AK4551/4FKD-3.5-BASALTGREY	54551042401 F	200
5	27.50	AK4551/5FKD-3.5-BASALTGREY	54551052401 F	200
6	31.00	AK4551/6FKD-3.5-BASALTGREY	54551062401 E	100
7	34.50	AK4551/7FKD-3.5-BASALTGREY	54551072401 E	100
8	38.00	AK4551/8FKD-3.5-BASALTGREY	54551082401 D	50
9	41.50	AK4551/9FKD-3.5-BASALTGREY	54551092401 D	50
10	45.00	AK4551/10FKD-3.5-BASALTGREY	54551102401 D	50
11	48.50	AK4551/11FKD-3.5-BASALTGREY	54551112401 D	50
12	52.00	AK4551/12FKD-3.5-BASALTGREY	54551122401 D	50
13	55.50	AK4551/13FKD-3.5-BASALTGREY	54551132401 D	50
14	59.00	AK4551/14FKD-3.5-BASALTGREY	54551142401 D	50
15	62.50	AK4551/15FKD-3.5-BASALTGREY	54551152401 D	50
16	66.00	AK4551/16FKD-3.5-BASALTGREY	54551162401 D	50
17	69.50	AK4551/17FKD-3.5-BASALTGREY	54551172401 D	50
18	73.00	AK4551/18FKD-3.5-BASALTGREY	54551182401 D	50
19	76.50	AK4551/19FKD-3.5-BASALTGREY	54551192401 D	50
20	80.00	AK4551/20FKD-3.5-BASALTGREY	54551202401 D	50

## Accessoires

Figure	Designation	Article Number
	Series AK(Z)4551 with pull relief	Order Data: on request

## Ratings

UseGroup						
	B	C	D			
Rated Voltage	300 V	-	300 V	160 V		
Rated Current	10 A	-	10 A	10 A		
Overvoltage Category				III		
Rated Wire Size	min					max
	- solid	AWG 26-16	-	AWG 26-16	0.14 mm <sup>2</sup> (3 A)	2.5 mm <sup>2</sup> (10 A)
- stranded	AWG 26-16	-	AWG 26-16	0.14 mm <sup>2</sup> (3 A)	1.5 mm <sup>2</sup> (10 A)	
Test Voltage	1.60 kV	-	1.60 kV	2.5 kV		
Pollution Degree				3		